

REV	ECN No.	DESCRIPTION	DESIGN	DATE
A0		Release	吴丹平	2017.06.19

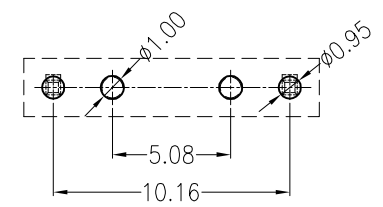
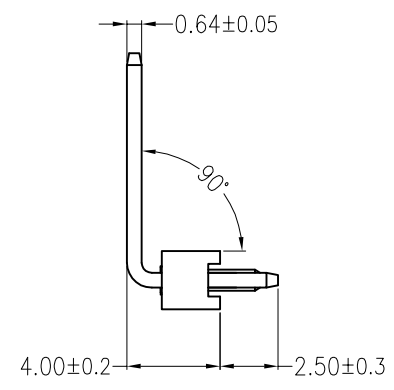
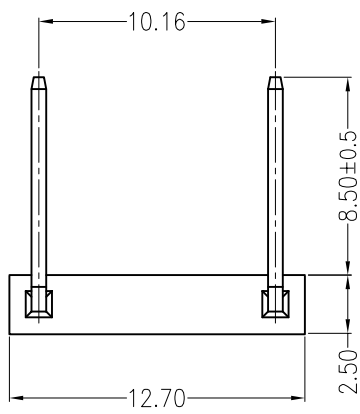

Board Layout

主要技术参数 Main Specifications

- 线数 (Poles): 02 to 10
- 接触电阻 (Contact resistance): $\leq 20m\Omega$
- 绝缘电阻 (Insulation resistance): $\geq 1000M\Omega$
- 额定电压 (Rated voltage): 250V AC DC
- 额定电流 (Rated current): 2.0A AC DC
- 耐电压 (Withstand Voltage): 1500V AC/minute
- 温度范围 (Temperature Range): $-40^{\circ}C \sim +110^{\circ}C$

ORDER INFORMATION:

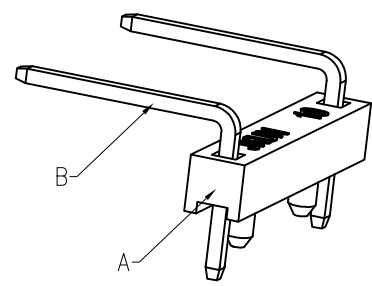
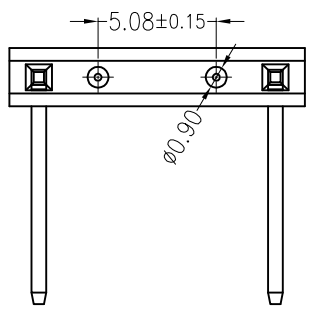
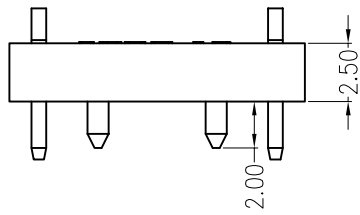
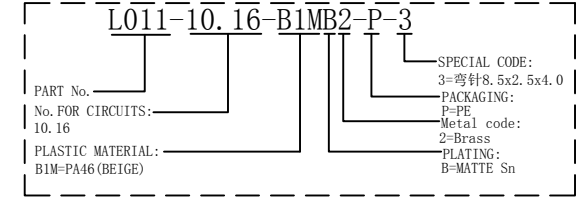

ITEM	COMPONENT	Q'TY	MATERIAL	FINISH
C				
B	CONTACT	2 PCS	Brass	Sn-plated
A	HOUSING	1 PCS	PA46	UL 94V-0, COLOR:BEIGE

东莞市高迪电子有限公司
 DONG GUAN GAO DI ELECTRONICS CO., LTD

TITLE: L011-10.16-03P
 10.16mmPITCH 90°WAFER DIP TYPE

X.±0.5	X.±5'	USE: CUSTOMER	PART NO.: L011-10.16-B1MB2-P-3
.X±0.3	.X±2'		
.XX±0.25	.XX±1'	APPD: 邵敬和	DWG NO.: GCCP-0498
--	--	CHKD: 田峰	
⊕	◁	DR: 吴丹平	SCALE: 1 : 1
UNITS: mm			SHEET: 1 / 1

定制品

起订量

50000PCS

REV	DESCRIPTION	DESIGN	DATE
A0	Release	吴丹平	2016.09.20

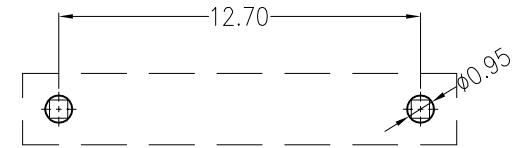
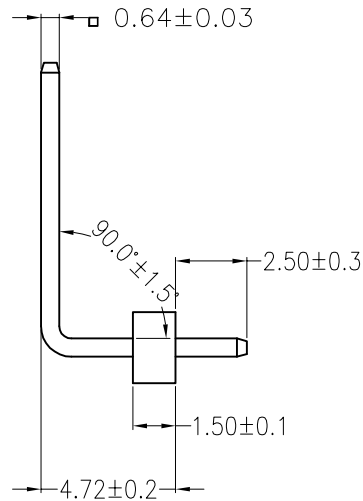
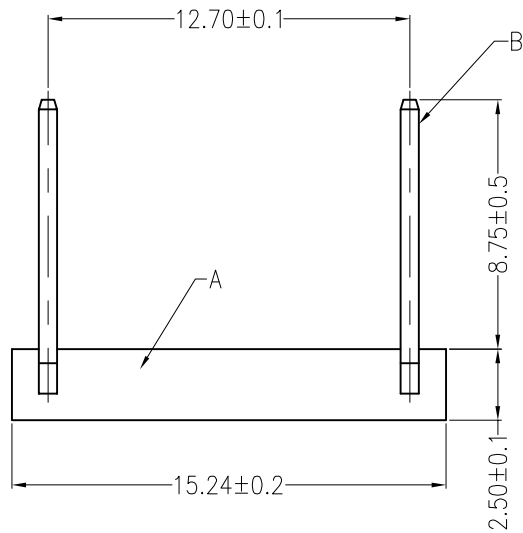

Board Layout
General Tolerance: ±0.05

主要技术参数 Main Specifications

- 线数 (Poles): 02 to 10
- 接触电阻 (Contact resistance): ≤20mΩ
- 绝缘电阻 (Insulation resistance): ≥1000MΩ
- 额定电压 (Rated voltage): 250V AC DC
- 额定电流 (Rated current): 2.0A AC DC
- 耐电压 (Withstand Voltage): 1500V AC/minute
- 温度范围 (Temperature Range): -40°C ~ +110°C

ORDER INFORMATION:

L012-12.7-B1MB2-P-50	
PART No. _____	SPECIAL CODE: _____
No. FOR CIRCUITS: _____	50=弯针8.75*2.5*4.72
12.7	PACKAGING: _____
PLASTIC MATERIAL: _____	P=PE
B1M=PA46 (BEIGE)	Metal code: _____
	2=Brass
	PLATING: _____
	B=MATTE Sn

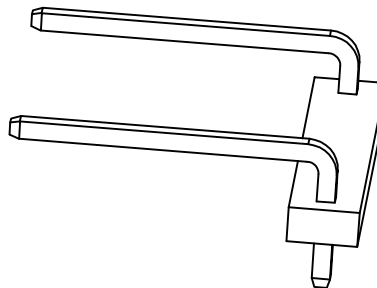
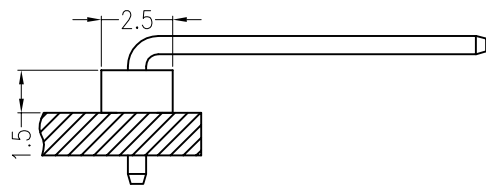

Assembly Layout

ITEM	COMPONENT	Q'TY	MATERIAL	FINISH
C				
B	CONTACT	2 PCS	Brass	Sn-plated
A	PEDESTAL	1 PCS	PA46	UL 94V-0, COLOR:BEIGE

东莞市高迪电子有限公司 DONG GUAN GAO DI ELECTRONICS CO., LTD			TITLE: -	
			12.7mmPITCH 90°WAFER DIT TYPE	
X.±0.5	X.±5°	USE:	PART NO.:	
.X±0.3	.X±2°	CUSTOMER	L012-12.7-B1MB2-P-50	
.XX±0.25	.XX±1°	APPD: 谭龙清	DWG NO.:	
--	--	CHKD: 田峰	GCCP-1128	
⊕	◁	UNITS: mm	DR: 蒋建银	SCALE: 1:1
				SHEET: 1/1